

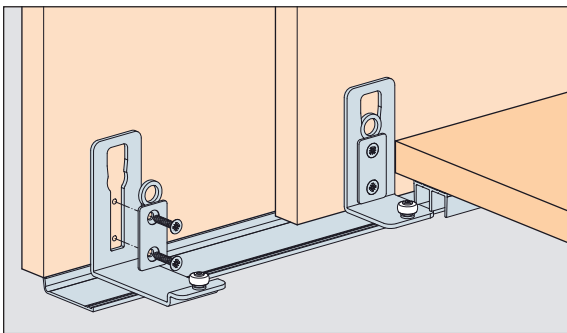

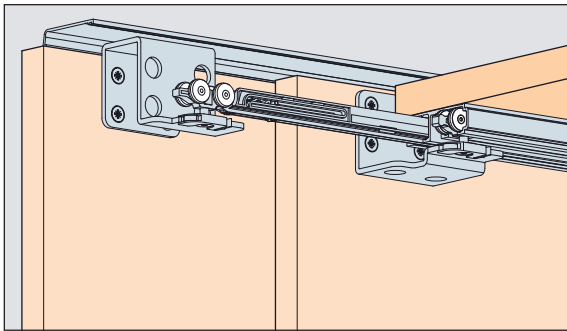

# Montageanleitung Mounting instructions Instructions de montage





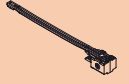







**Hawa Clipo** 16 H FS 2-bahng | 2 tracks | 2 voies















## Garnituren / Sets / Garnitures

<b>10 mm No. 053.3373.071</b>
<b>19 mm No. 053.3373.072</b>
 2x
 2x
 2x

**Für zusätzliches Dämpfen in Öffnungsrichtung 1 x bestellen.**  
Order 1x for additional soft closing function in opening direction.  
Commander 1x pour un amortissement supplémentaire dans le sens de l'ouverture.

<b>2 Türen Doors Portes</b>	10mm <b>No. 053.3374.071</b>	19mm <b>No. 053.3374.072</b>
 2x	 2x	
 2x	 2x	 2x
 2x	 2x	
 2x	 4x	
 1x	 1x	 26x

<b>3 Türen Doors Portes</b>	10mm <b>No. 053.3375.071</b>	19mm <b>No. 053.3375.072</b>
 3x	 3x	
 2x	 2x	 2x
 4x	 4x	
 1x	 3x	 6x
 36x	 2x	

## Einbau Muffe / Sleeve mounting / Montage de manchon

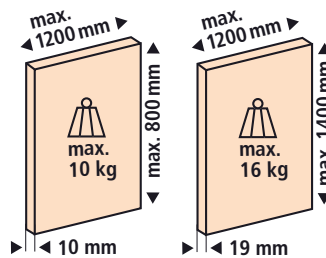
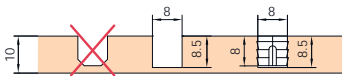

## Zubehör / Accessories / Accessoires

### Doppelaufschiene, Alu eloxiert, gelocht, zum Schrauben

Double running track, aluminium anodized, pre-drilled, for screw fixing  
Rail de roulement double, en alu anodisé, perforé, à visser

Gr./Size	Art. No.
2500 mm	053.3339.250
3500 mm	053.3339.350
6000 mm	053.3339.600

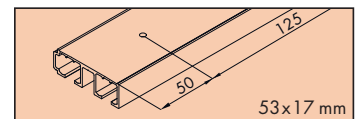

### Doppelführungsschiene, Alu eloxiert, gelocht, zum Schrauben

Double guide track, aluminium anodized, pre-drilled, for screw fixing  
Rail de guidage double, alu anodisé, perforé, à visser

Gr./Size	Art. No.
2200 mm	053.3261.220
2400 mm	053.3261.240
4800 mm	053.3261.480

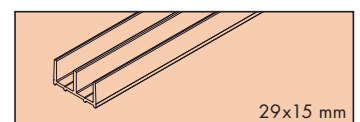

### Abdeckprofil, Alu eloxiert, oben/unten\*\*

Cover profile, aluminium anodized, top/bottom\*\*  
Profil de recouvrement, en alu anodisé, haut/bas\*\*

Gr./Size	Art. No.
2500 mm	056.3122.250
6000 mm	056.3122.600

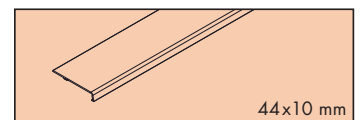

**\*\* 2 mm Doppelklebeband verwenden / Use 2 mm double-sided adhesive tape / Utiliser un 2 mm ruban adhésif à double face**

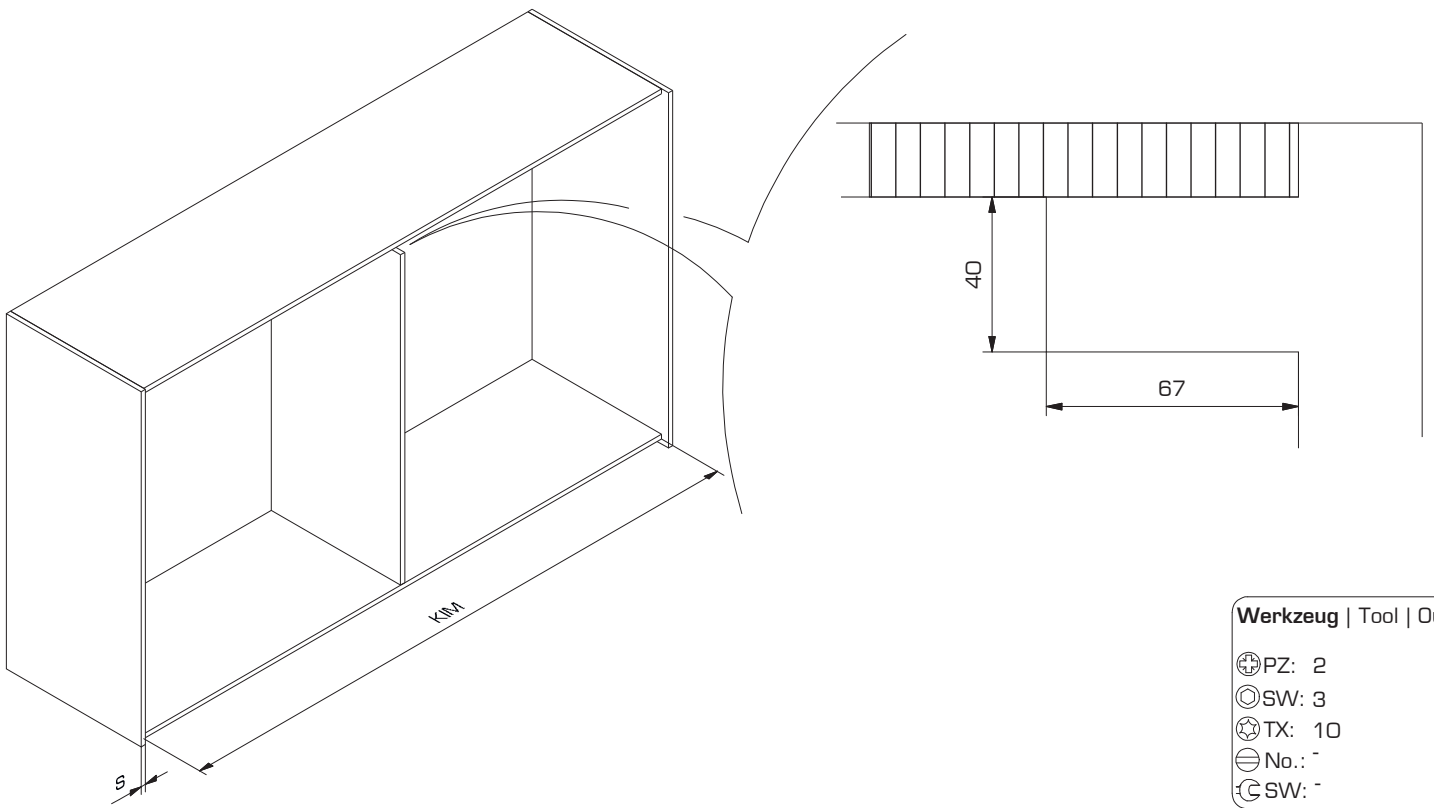

- Werkzeug | Tool | Outil**
- ⊕ PZ: 2
  - ⊙ SW: 3
  - ☆ TX: 10
  - ⊖ No.: -
  - ⊗ SW: -

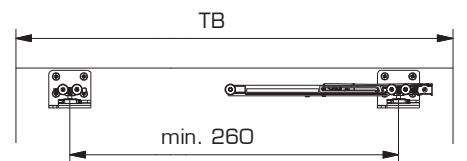
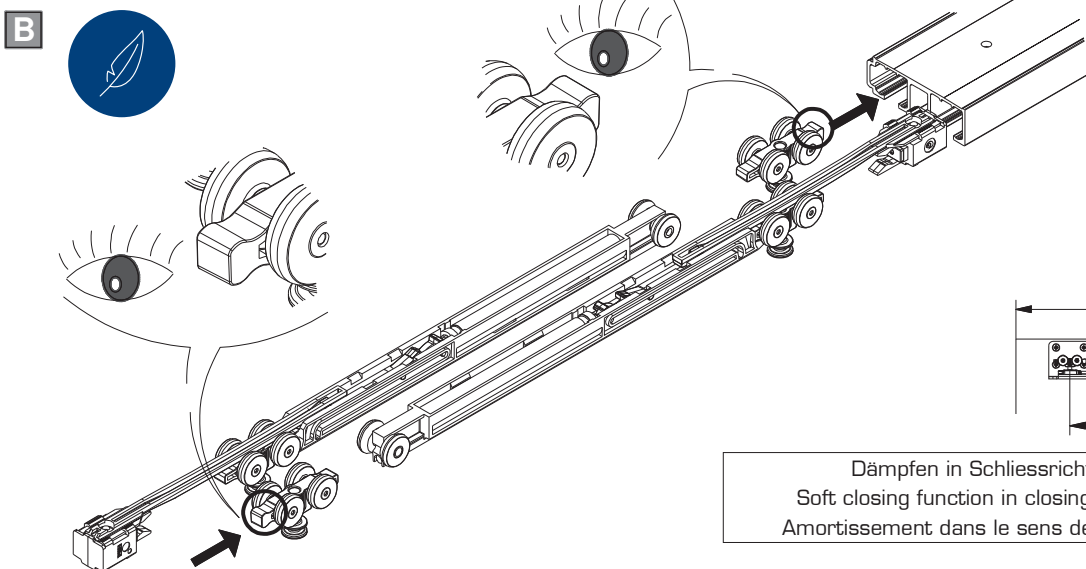
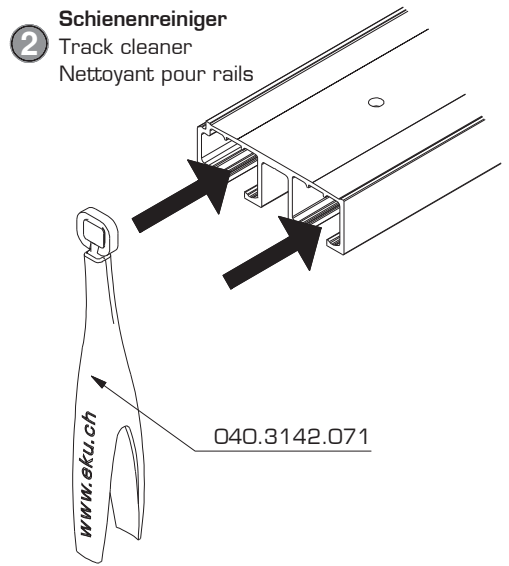
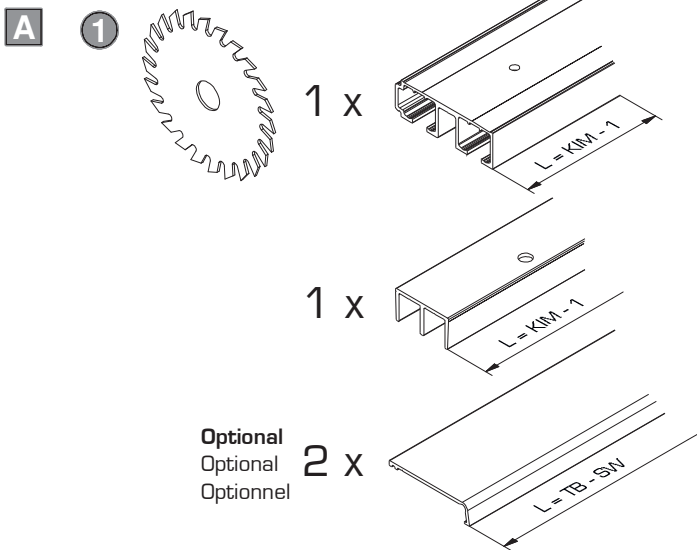

Dämpfen in Schliessrichtung Soft closing function in closing direction Amortissement dans le sens de fermeture	min. 260
--	----------

**C** Optional  
Option  
Optionnel

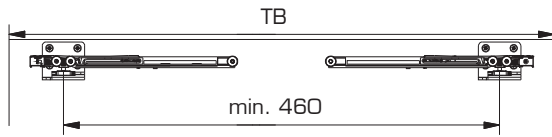

		Bestellen / Order / Commander
Dämpfen in Schliess- und Öffnungsrichtung Soft closing function in closing and opening direction Amortissement dans le sens de fermeture et d'ouverture	min. 460	10 mm = - 10 kg 053.3373.071
Dämpfen in Schliess- und Öffnungsrichtung Soft closing function in closing and opening direction Amortissement dans le sens de fermeture et d'ouverture	min. 460	19 mm = - 16 kg 053.3373.072

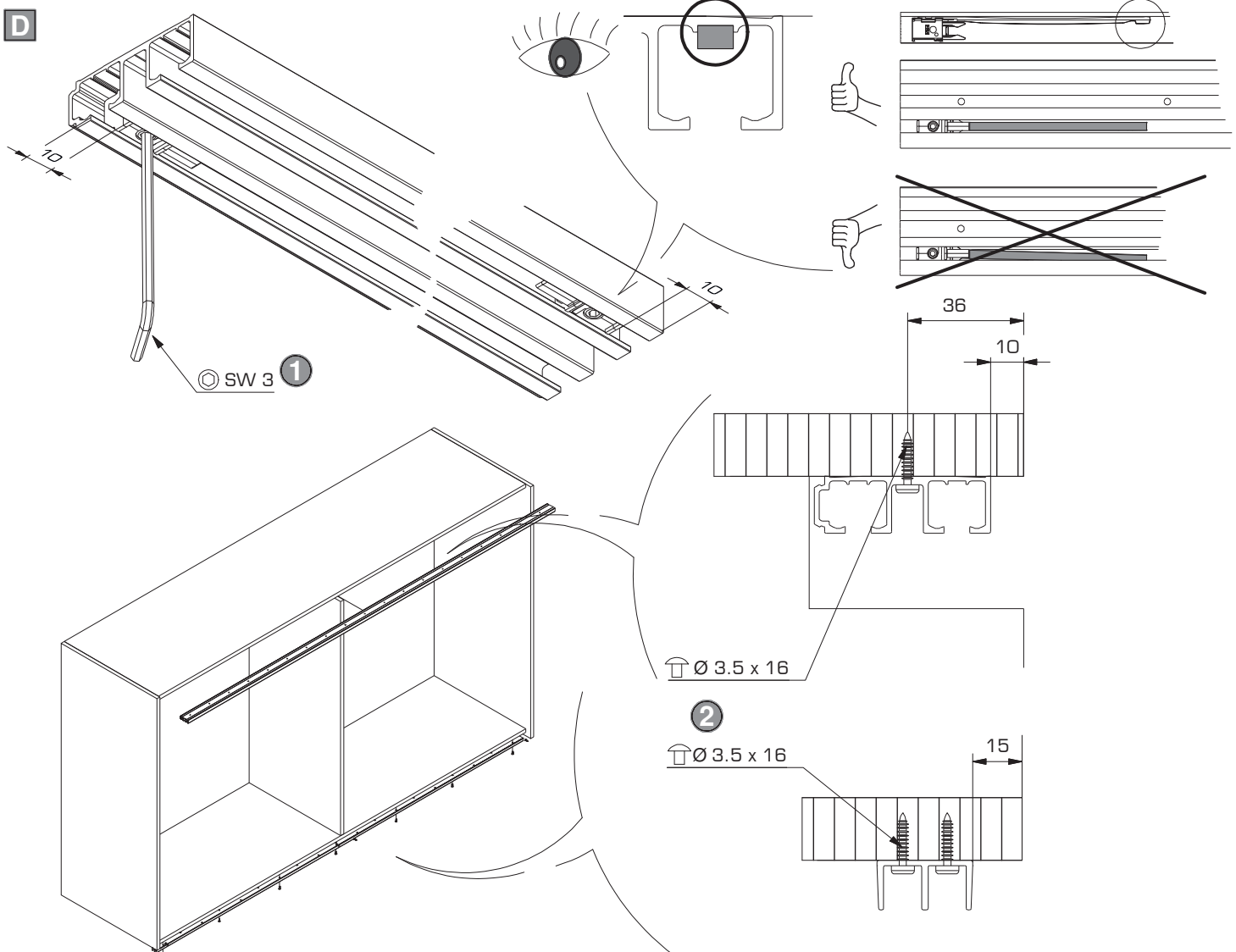
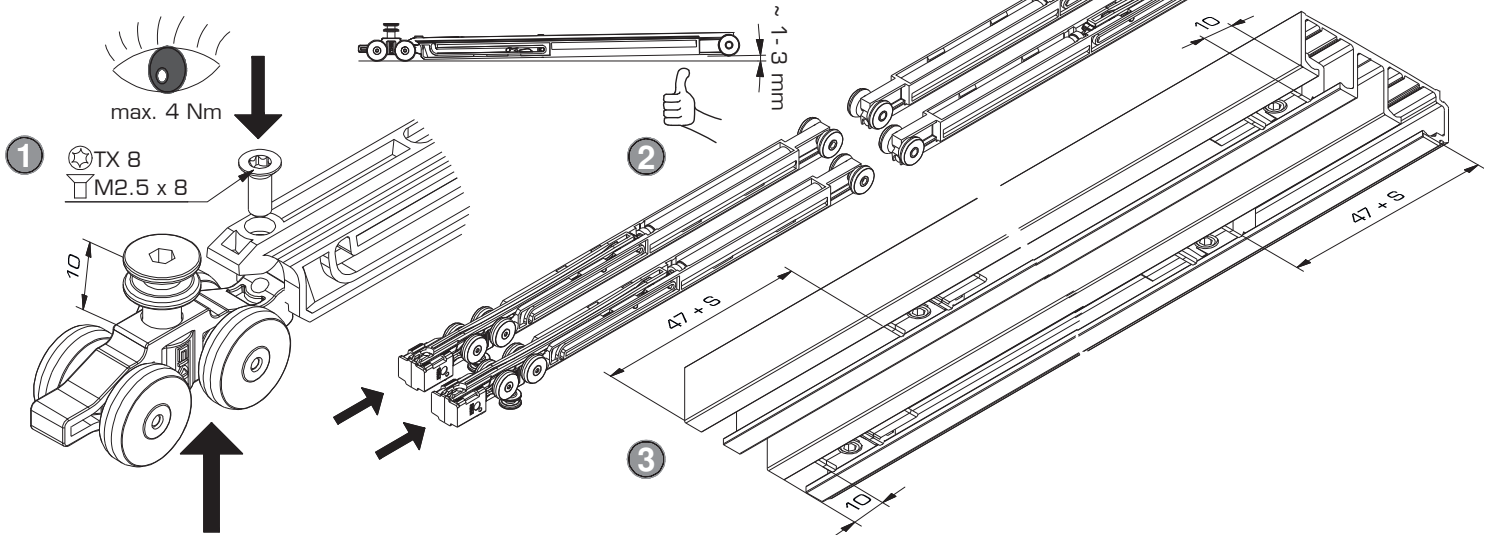

**E** Türe | Door | Porte

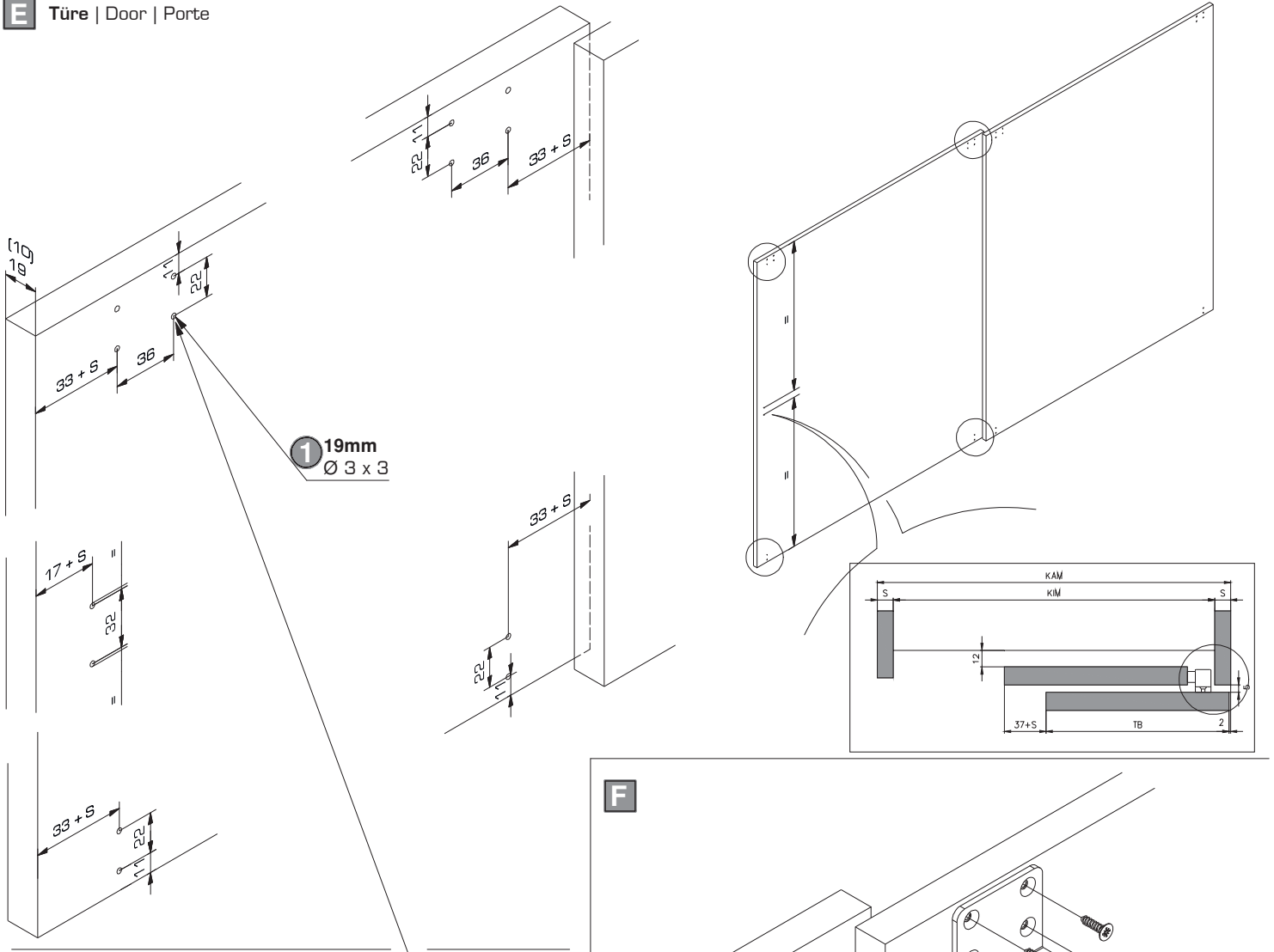

Türen  
Doors 10 mm  
Portes

**1** 10mm  
Ø 8 x 8.5

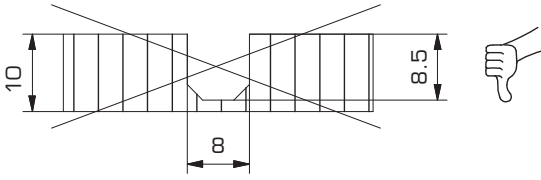
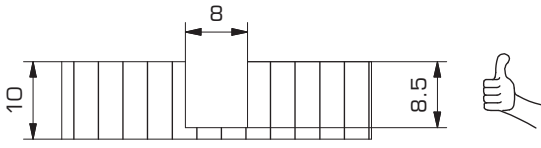

**1** Kleben  
Glue fixing  
Coller

**2** Einschlagen  
Drive into  
Planter

**3** 1 h trocknen  
1 h to cure  
1 h sécher

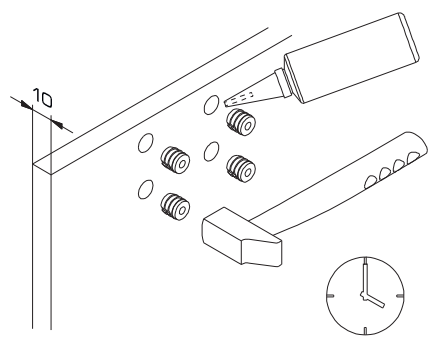

**F**

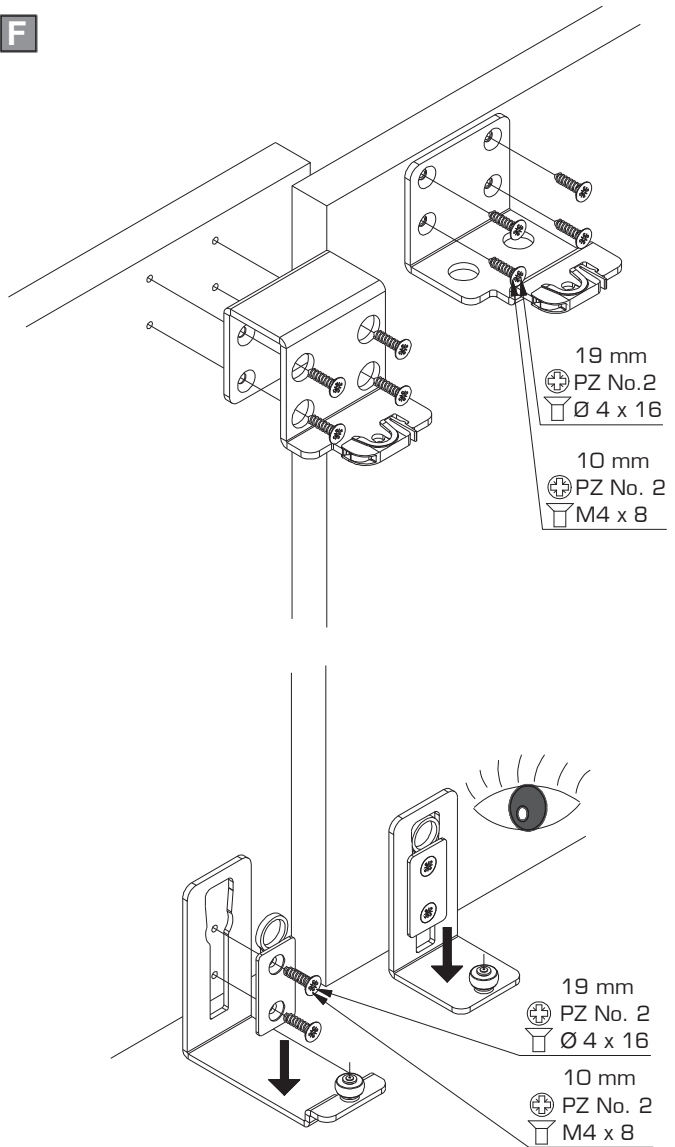

19 mm  
PZ No.2  
Ø 4 x 16

10 mm  
PZ No. 2  
M4 x 8

19 mm  
PZ No. 2  
Ø 4 x 16

10 mm  
PZ No. 2  
M4 x 8

G

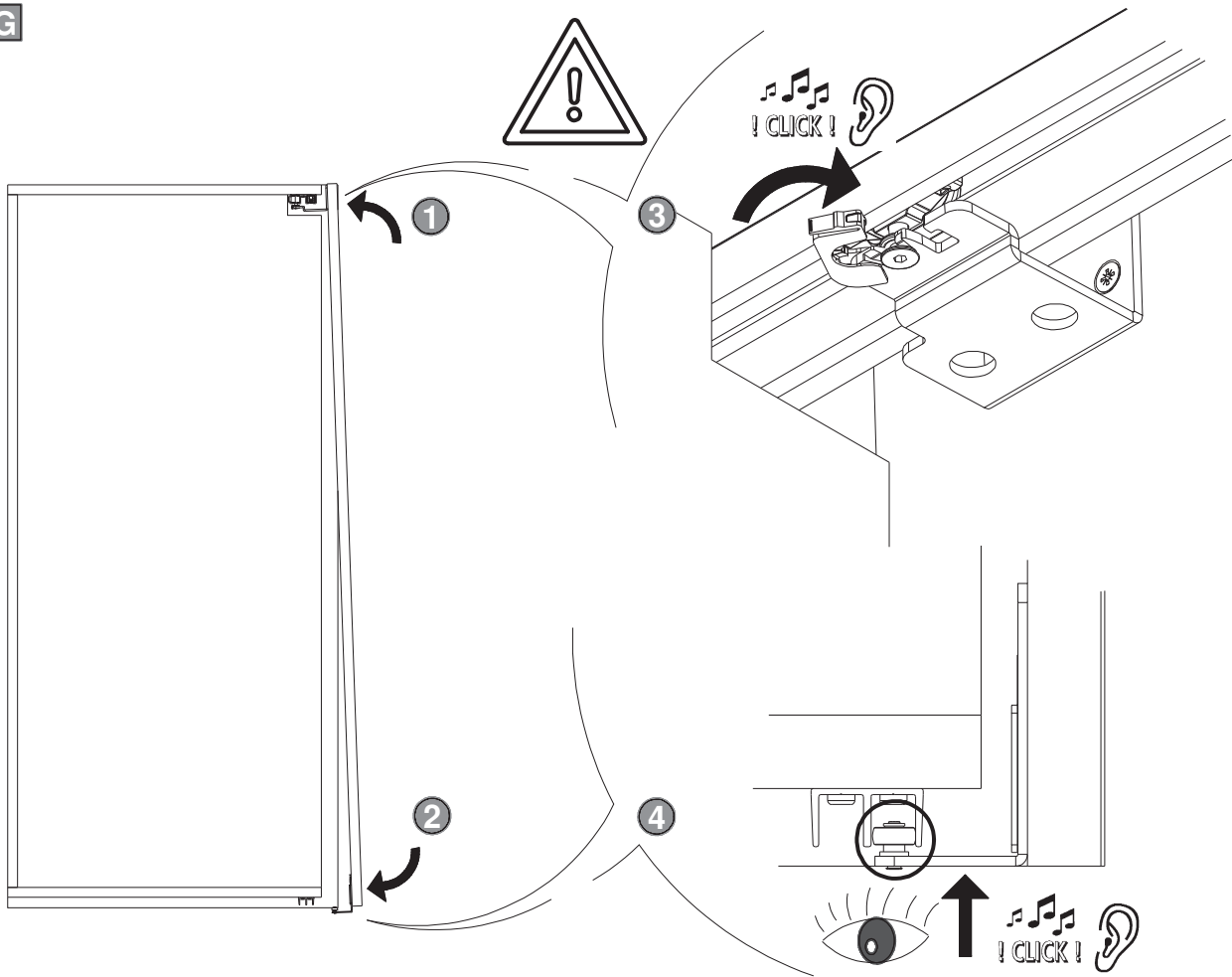

H

- 2 Türen
- 2 Doors
- 2 Portes

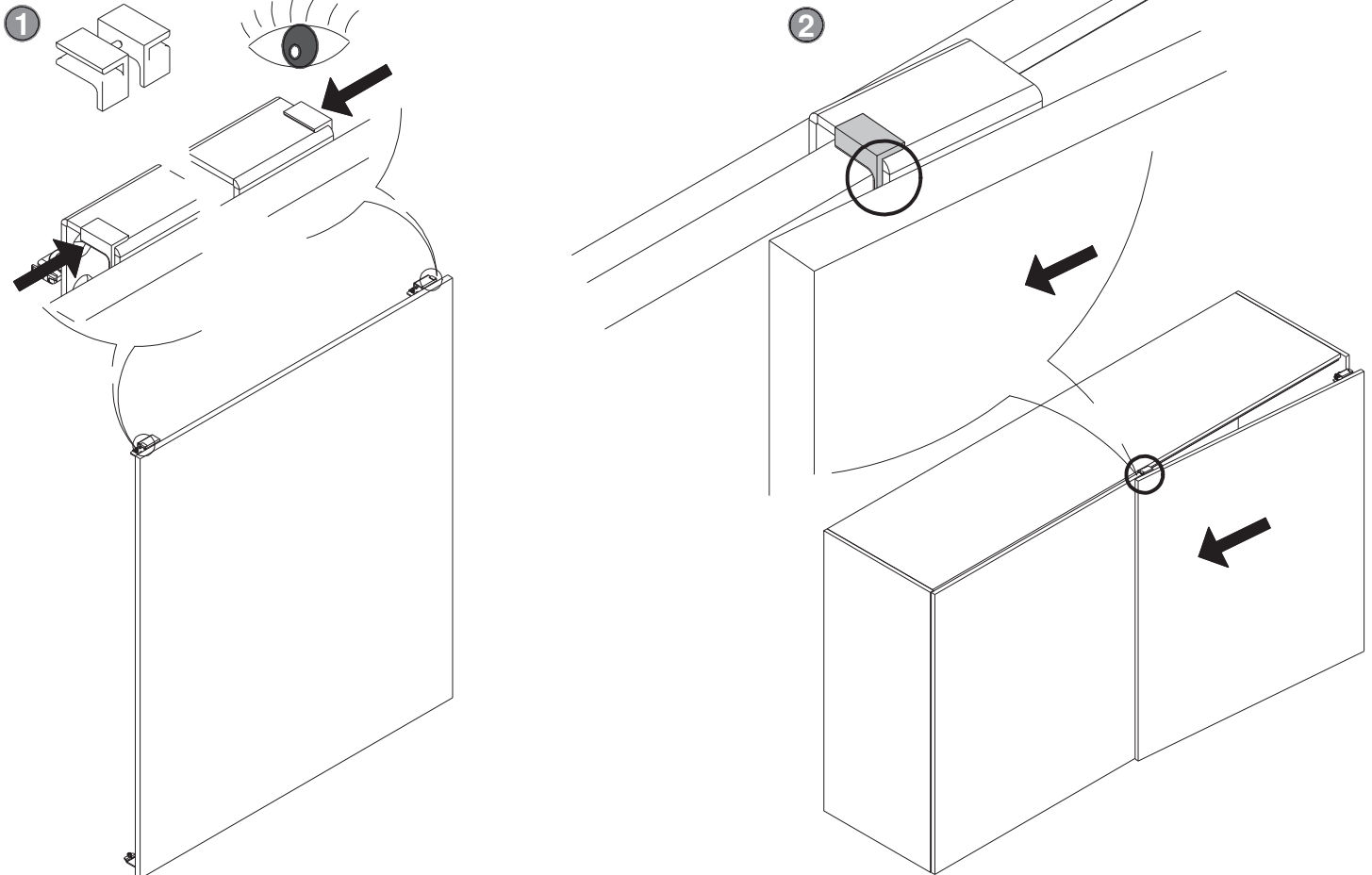

I

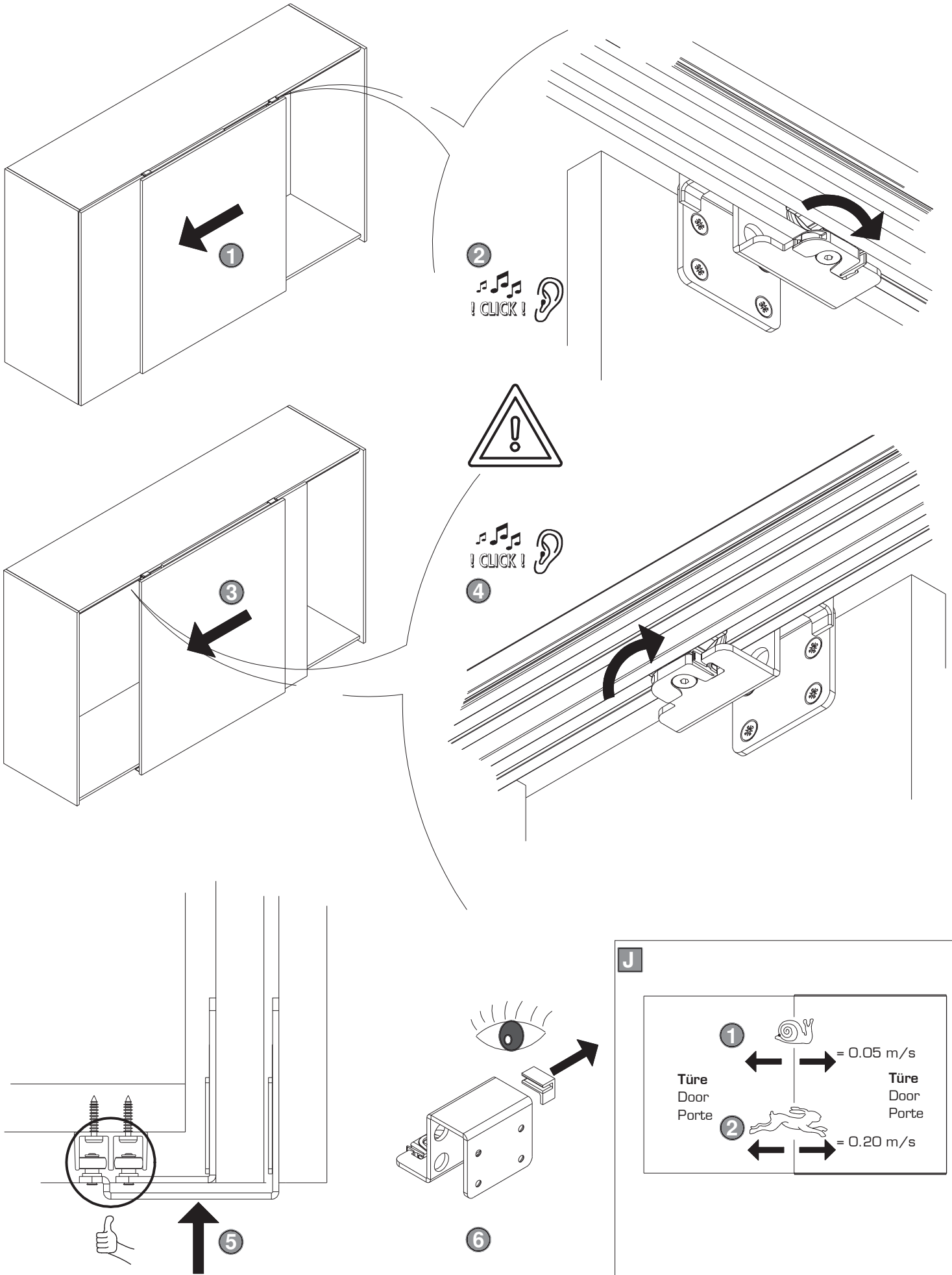

**K** 3 Türen  
3 Doors  
3 Portes

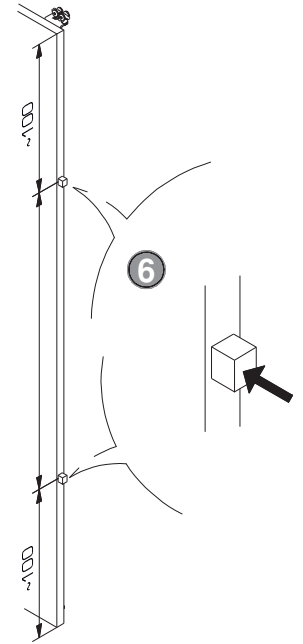
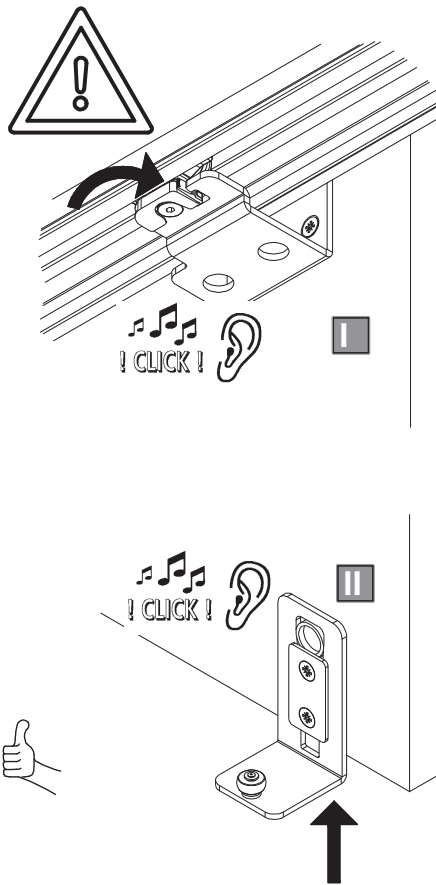
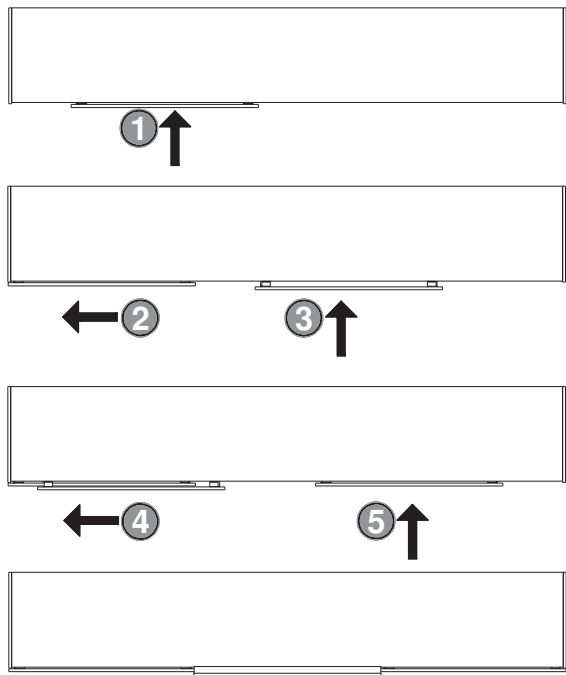

**L** Optional  
Optional  
Optionnel

Art. No. 055.3130.

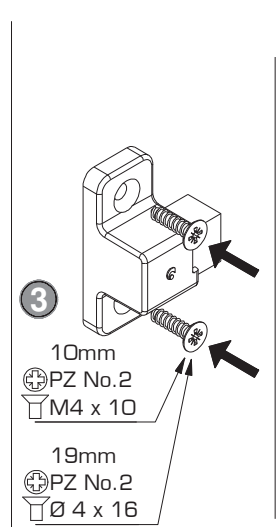
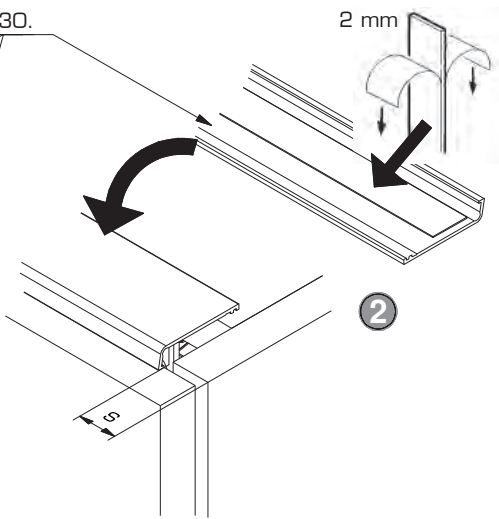
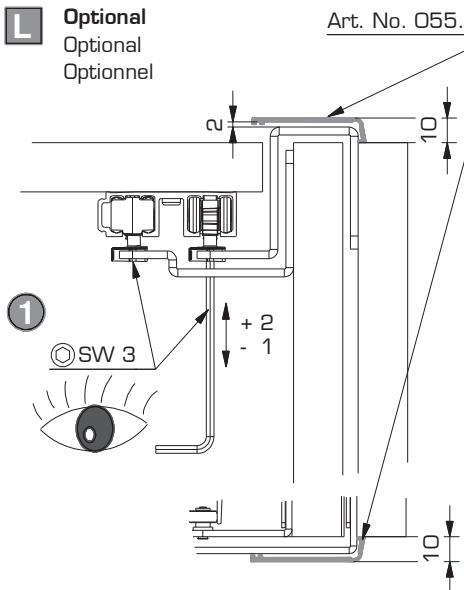

**M** Türdemontage  
Door dismounting  
Demontage de la porte

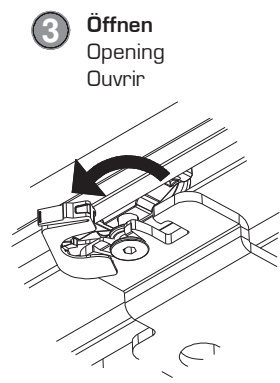
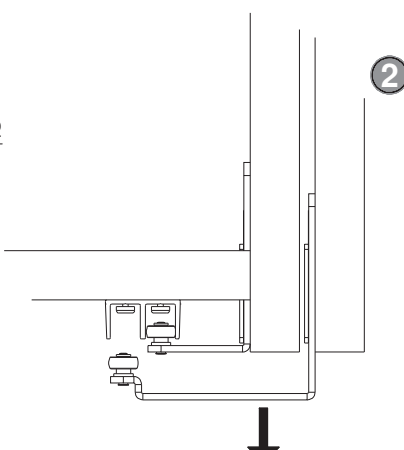
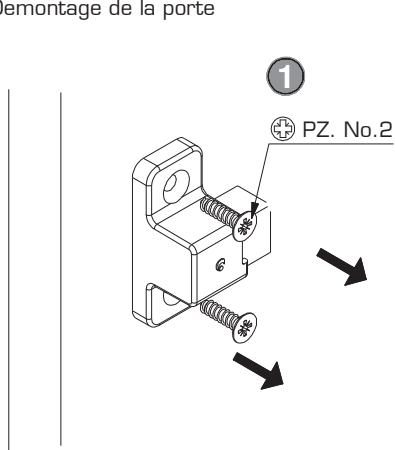

Einbaubeispiele/Mounting examples/Exemples de montage

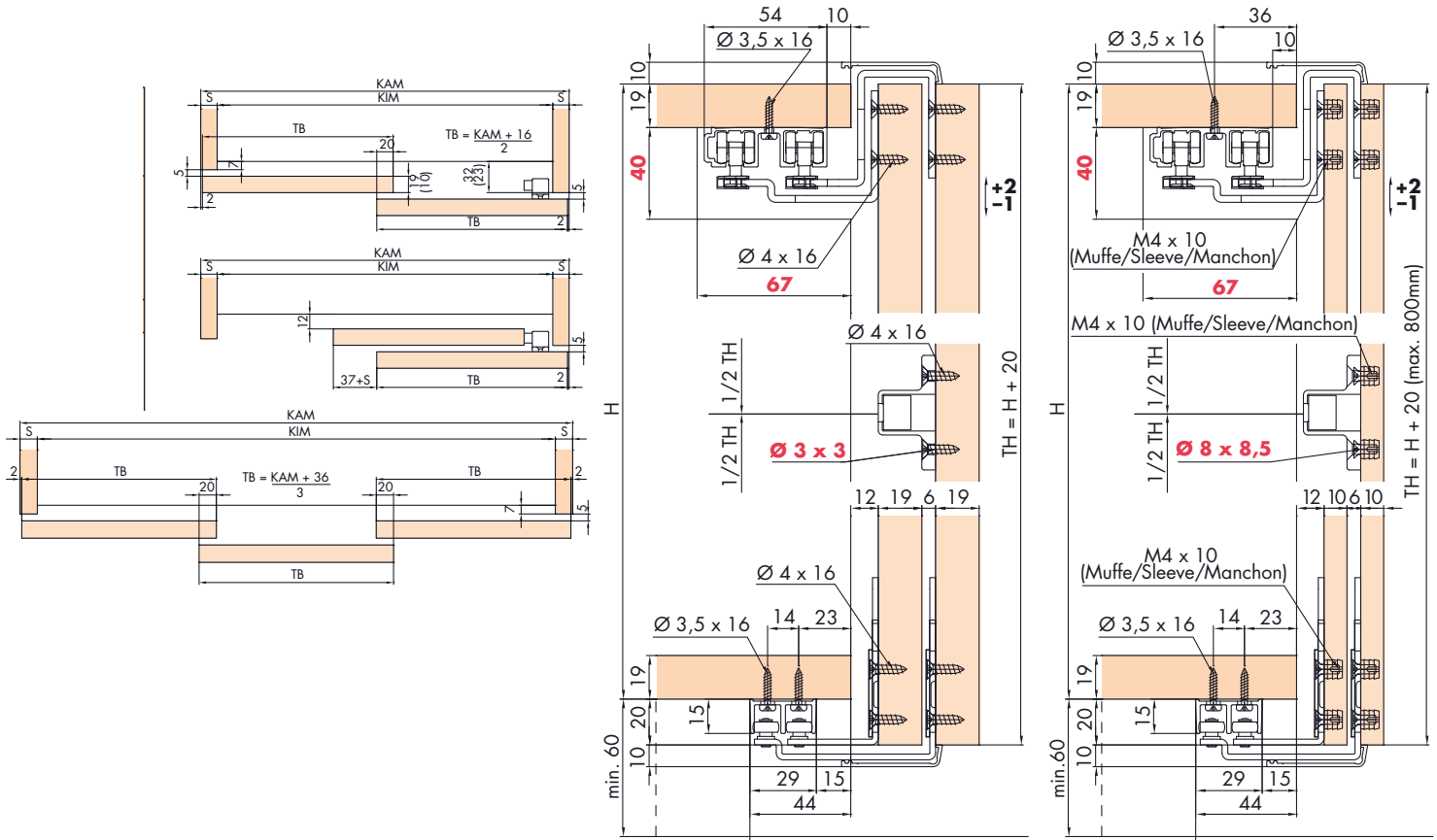

KIM

